

REV	DESCRIPTION	ECN #	CHG BY	DATE	APP'D
A	CONVERTED TO 3D	14859	EZR	11/06/18	TAS

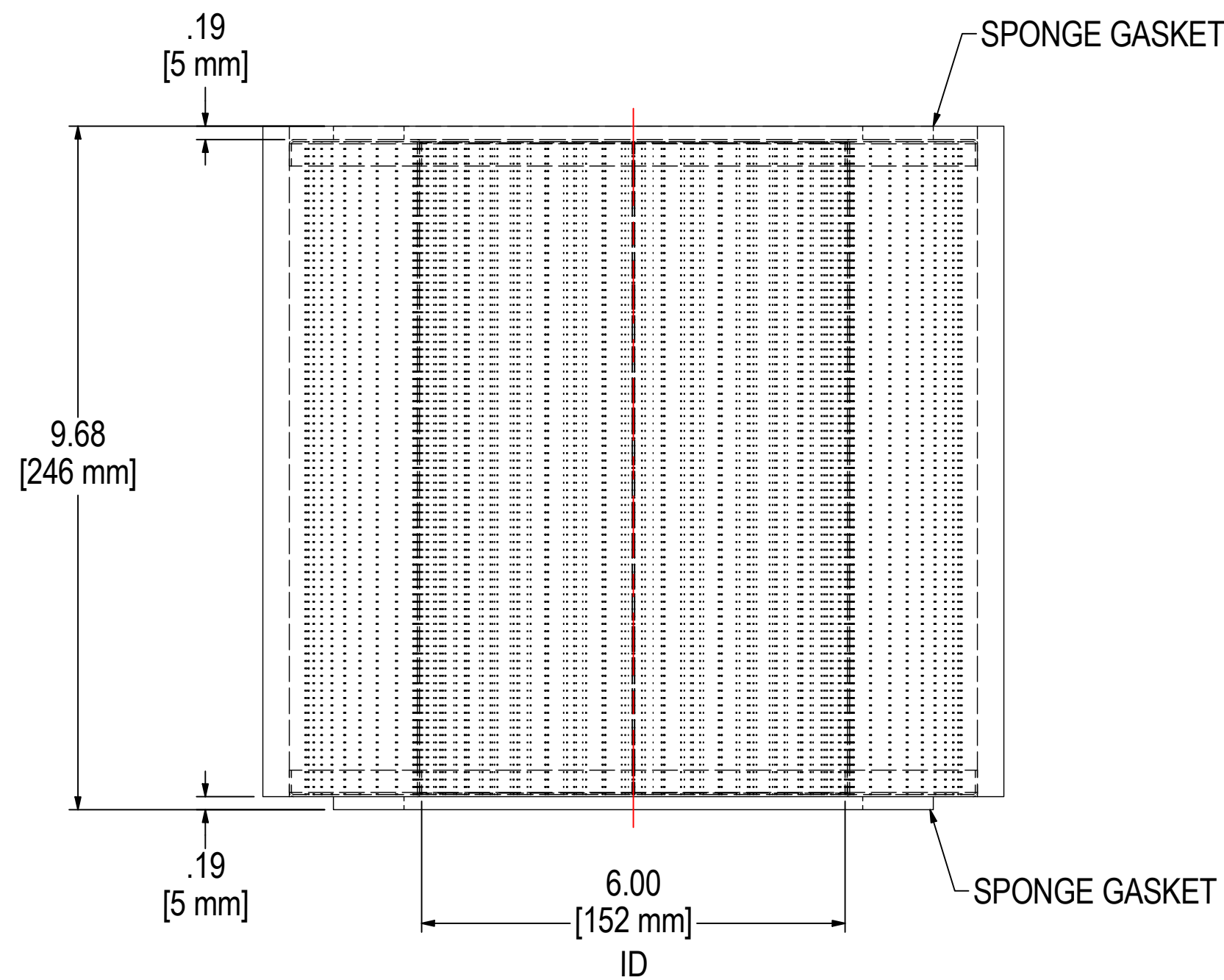
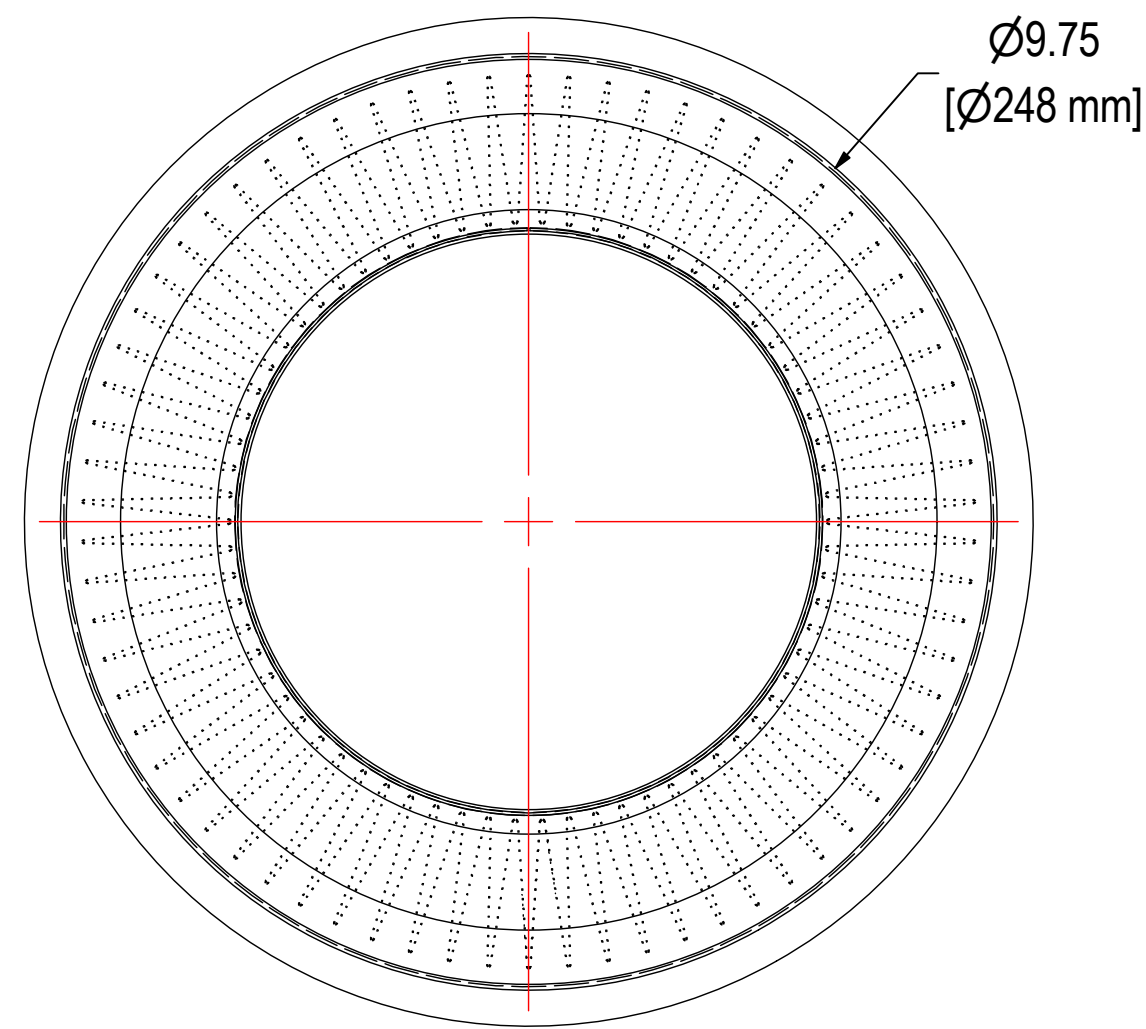

ELEMENT SPECS		
PART NUMBER	245P	
MATERIAL	Polyester	
FLOW RATE	880 CFM	1495 m ³ /hr
SURFACE AREA	14.0 ft ²	1.3 m ²
I.D.	SEE DRAWING	SEE DRAWING
O.D.	SEE DRAWING	SEE DRAWING
HEIGHT	SEE DRAWING	SEE DRAWING